

Latham Surface-Line Series Aluminium Expansion Joint Cover with Stainless Steel Cover Plate FXS

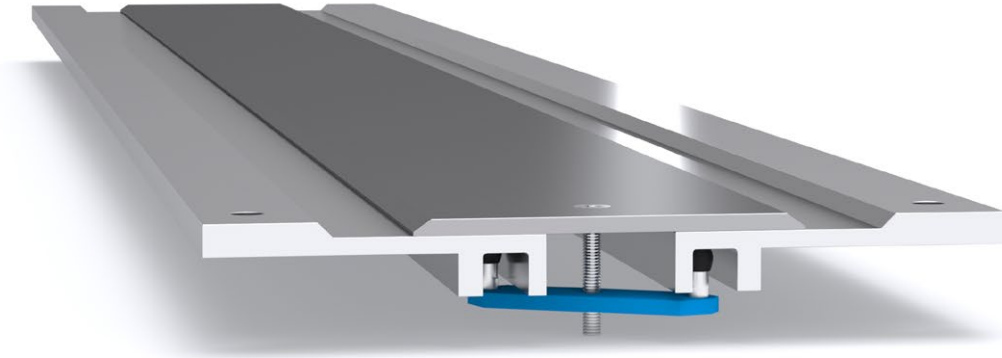

Illustrated: FXS-25

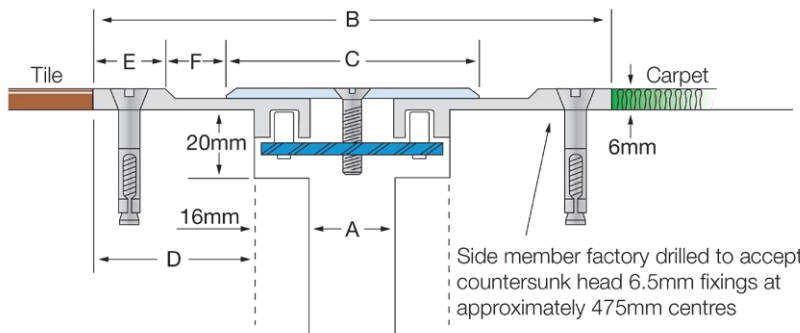

Stainless Steel Code smooth deck	A	B	C	D	E	F	Movement	Total Available Movement	Overall Depth	Cover Plate Thickness
FXS-25	25	146	75	46	20	18	+25/-15mm	40mm	Surface Mounted	3mm
FXS-50	50	171	100	46	20	18	+/-25mm	50mm	Surface Mounted	3mm
FXS-75	75	196	125	46	20	18	+/-25mm	50mm	Surface Mounted	3mm
FXS-100	100	221	150	46	20	18	+/-25mm	50mm	Surface Mounted	3mm
FXS-150	150	271	200	46	20	18	+/-25mm	50mm	Surface Mounted	4mm

FEATURES

- Aluminium floor expansion joint cover with a stainless steel cover plate.
- Designed to finish flush with the surrounding floor finish (can be suitably packed up to height if required).
- Installed into a minimal recess, or providing the joint width is 62mm or larger, the system can simply hang over the edge of the slabs and no recess is required.

MATERIALS

- Aluminium 6063-T5 mill finish alloy.
- 304 Grade, 2B finish stainless steel cover plates.
- Supplied in 3050mm lengths.
- Spring steel treated centering bar with elongated spherical rods (at ~475mm centres).

FIXINGS

- Side members pre-drilled at ~475mm centres to accept countersunk head 6.5mm fixings.
- We recommend Latham Thixotropic Epoxy Adhesive be used in conjunction for superior securing.

FURTHER TECHNICAL SPECIFICATIONS

- [Website Link - PDF and DWG Details](#)
- [Product Information](#)
- [Joint Specifications](#)
- [Fire Rated Systems](#)
- [Full Product Catalogue](#)
- [Architectural Specifications](#)
- [Warranty](#)



multi directional
6-way movement



indoor use



fire rated (joint
widths >50mm)