

Latham Surface-Line Series Aluminium Expansion Joint Cover  
**FXAL**

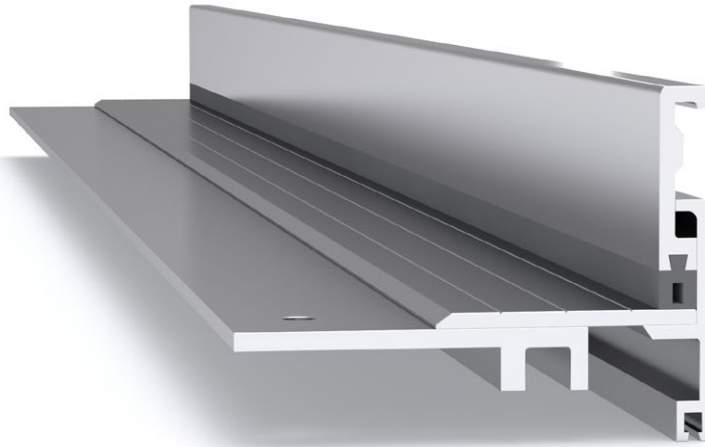

Illustrated: FXAL-25

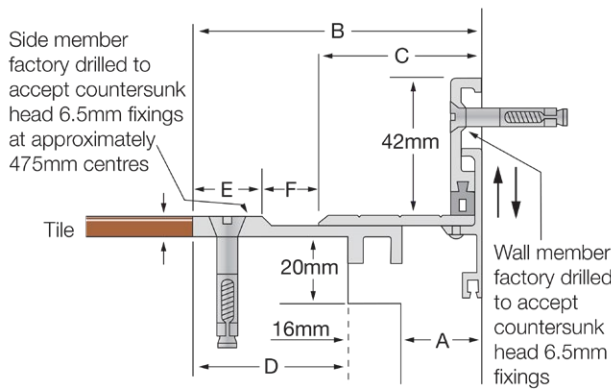

Aluminium Code ribbed deck	A	B	C	D	E	F	Movement	Total Available Movement	Overall Depth	Cover Plate Thickness
FXAL-25	25	87	50	49	20	18	+20/-15mm	35mm	Surface Mounted	3mm
FXAL-50	50	112	75	49	20	18	+20/-15mm	35mm	Surface Mounted	3mm
FXAL-75	75	137	100	49	20	18	+20/-15mm	35mm	Surface Mounted	4mm
FXAL-100	100	162	125	49	20	18	+20/-15mm	35mm	Surface Mounted	5mm
FXAL-125	125	187	150	49	20	18	+20/-15mm	35mm	Surface Mounted	5mm

**FEATURES**

- Aluminium floor-to-wall expansion joint cover.
- Designed to finish flush with the surrounding floor finish (can be suitably packed up to height if required).
- Installed into a minimal recess, or providing the joint width is 62mm or larger, the system can simply hang over the edge of the slabs and no recess is required.

**MATERIALS**

- Aluminium 6063-T5 mill finish alloy.
- Supplied in 3050mm lengths.

**FIXINGS**

- Side and wall members pre-drilled at ~475mm centres to accept countersunk head 6.5mm fixings.
- We recommend Latham Thixotropic Epoxy Adhesive be used in conjunction for superior securing.

**FURTHER TECHNICAL SPECIFICATIONS**

- [Website Link - PDF and DWG Details](#)
- [Product Information](#)
- [Joint Specifications](#)
- [Fire Rated Systems](#)
- [Full Product Catalogue](#)
- [Architectural Specifications](#)
- [Warranty](#)



multi directional  
6-way movement



indoor use



fire rated (joint  
widths >50mm)