

Latham Carpet-Line Series Aluminium Expansion Joint Cover
SCAL

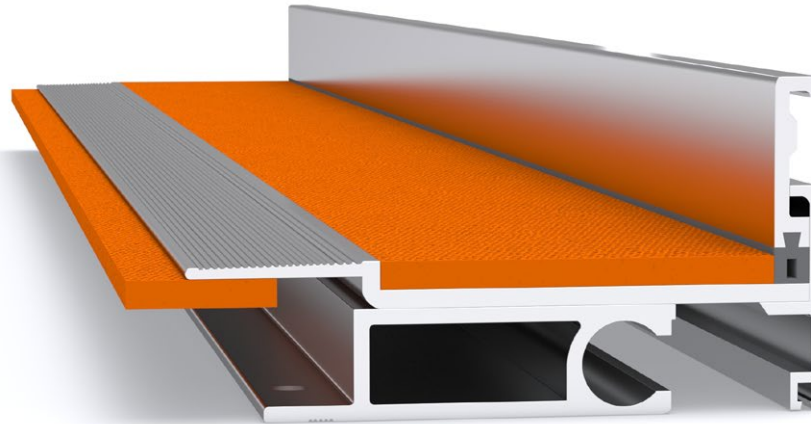

Illustrated: SCAL-25

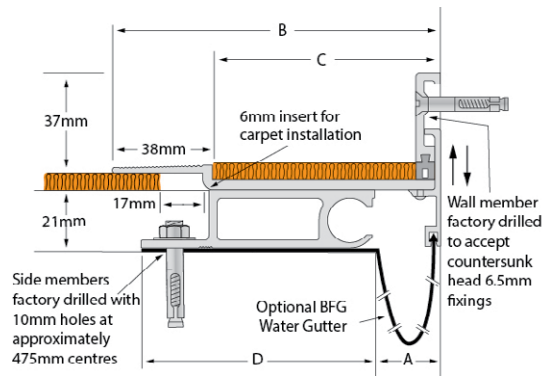

Aluminium Code ribbed deck	A	B	C	D	Movement	Total Available Movement	Overall Depth	Cover Plate Thickness
SCAL-25	25	167	127	90	+/-17mm	34mm	21mm	9mm
SCAL-50	50	167	127	90	+/-17mm	34mm	21mm	9mm
SCAL-75	75	167	127	90	+/-17mm	34mm	21mm	9mm
SCAL-100	100	167	127	90	+/-17mm	34mm	21mm	9mm

FEATURES

- Aluminium floor expansion joint cover.
- Suited to carpet flooring applications.
- These joint covers should be used in conjunction with carpet and underlay, direct stick carpet or carpet tiles.
- 30mm depth below carpet base.
- Installed in a preformed recess or cast-in.

MATERIALS

- Aluminium 6063-T5 mill finish alloy.
- Supplied in 3050mm lengths.

FIXINGS

- Side member pre-drilled at ~475mm centres for 10mm fasteners.
- Wall member pre-drilled at ~475mm centres to accept countersunk head 6.5mm fixings.

FURTHER TECHNICAL SPECIFICATIONS

- [Website Link - PDF and DWG Details](#)
- [Product Information](#)
- [Joint Specifications](#)
- [Fire Rated Systems](#)
- [Full Product Catalogue](#)
- [Architectural Specifications](#)
- [Warranty](#)



multi directional
6-way movement



indoor & out-
door use



VWS water
gutter