

SCAL Carpet-Line Series - Carpet View

Flexible Expansion Joint Cover

LATHAM AUSTRALIA PTY LTD
 14 TENNYSON ROAD GLADESVILLE 2111 AUSTRALIA
 Phone: 61 2 9879 7888 Fax: 61 2 9879 7666
 Web: www.latham-australia.com



Illustrated: SCAL-25 Scale: Approx. 95% Full Size
 All dimensions are to be verified before construction

Verified By..... Date.....

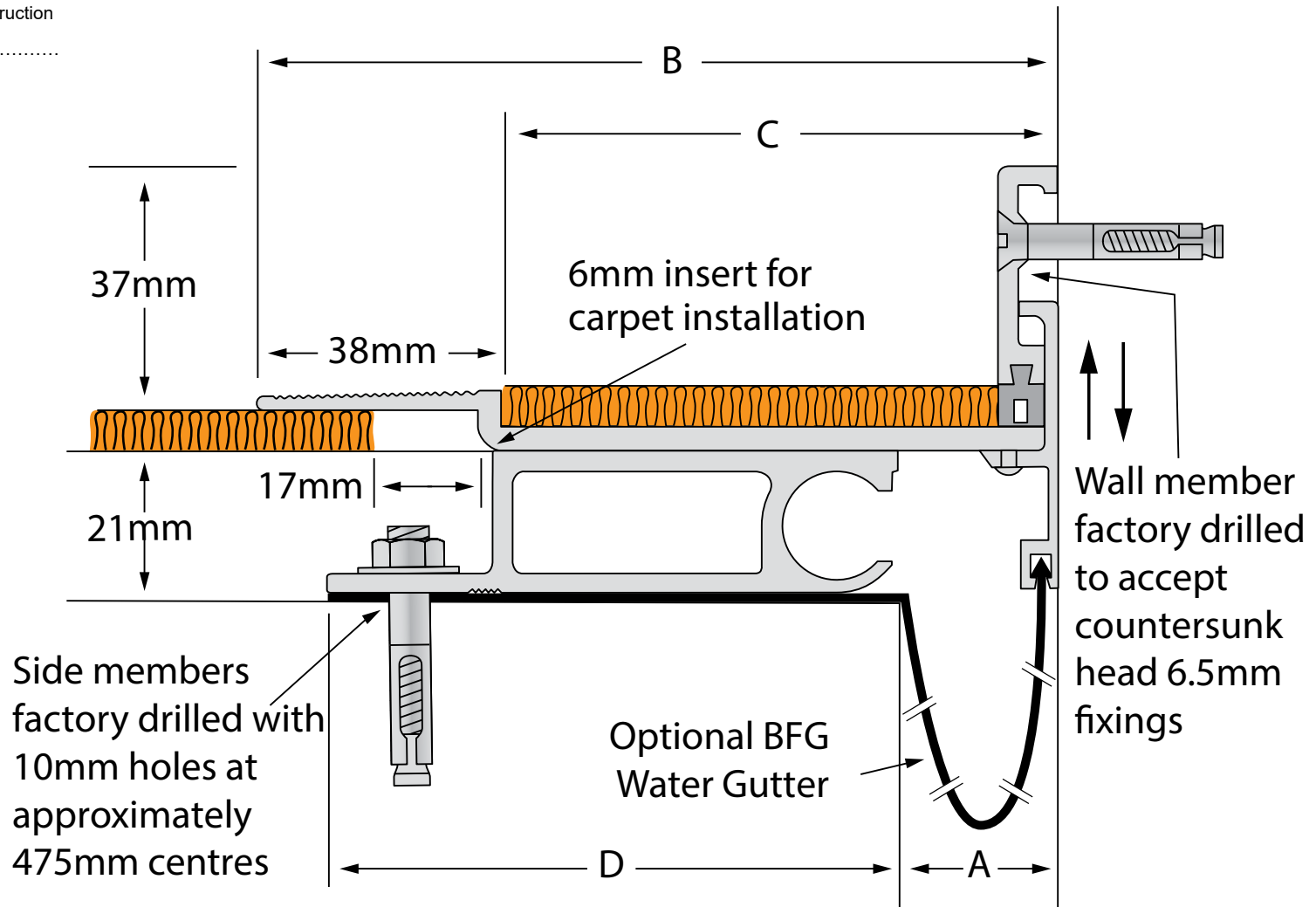

Aluminium Code	A	B	C	D	Movement	Total Available Movement	Overall Depth	Cover Plate Thickness
SCAL-25 ribbed deck	25	167	127	90	+/-17mm	34mm	21mm	9mm
SCAL-50	50	167	127	90	+/-17mm	34mm	21mm	9mm
SCAL-75	75	167	127	90	+/-17mm	34mm	21mm	9mm
SCAL-100	100	167	127	90	+/-17mm	34mm	21mm	9mm

All dimensions are in millimetres.

Interior applications only.
 All mechanical expansion joint fixings by others.
 Design subject to change without notice.

COPYRIGHT © 2026